



Product Highlights

- CO and differential dew point sensors
- Removes oils, solid particles, water and unpleasant odors
- Respirator CFM and sensor flow alarms
- Visual and audible alarm warnings
- Datalog - OSHA compliance records
- Portable - battery operated, rechargeable

AirGuard is an innovative next-generation solution in portable air quality products. It integrates breathing air filtration with sensors for Carbon monoxide (CO) and differential dew point for both safety and breathing air comfort.

Designed with the user in mind, AirGuard has an external easy-to-read display to communicate threats beyond general audible alarm warnings. The display is readable from over 30 feet allowing for a quick response when AirGuard detects a hazardous situation. Using its menu-driven interface, AirGuard is easy to operate. It provides a system status upon power up and most importantly keeps track of the sensor and function status and calibration interval. The AirGuard data log records all the real-time sensor data, calibration events, and diagnostic data over time. This data is easily downloadable to a PC using the removable USB drive for operational record keeping and OSHA compliance reporting.

The AirGuard model AGD15HA has a 15 CFM capacity with 1 output connection for NIOSH approved supplied-air respirators. AirGuard has a state of the art three-stage air filtration system that removes oils, water, solid particles, and unpleasant odors.

Ordering Information

Description	Part No.
AirGuard - 1 Worker, 15CFM with Hansen/Industrial Interchange Coupling	AGD15HA
Remote Alarm - Includes 100ft of cable	AGDRA
Calibration Kit - Includes Case, Regulator, Tubing, Quick Connector, 10PPM Cylinder and Zero Air Cylinder	AGDCK
Filter Replacement - 15CFM Filter Element Kit for all 3 stages of filtration	AGD15FK



AirGuard Series Portable Air Quality Box

15 CFM, 1 Airline Connection Technical Specifications

General Specifications

Display:	Backlit, 7" diagonal color display
Alarms:	User programmable
Air Flow Alarm Pt:	Carbon Monoxide 5 or 10 PPM < 3 CFM
Sensor Types:	Carbon Monoxide 0 to 50 ppm Dew Point -20°F to ambient Flow Rate 0 to 100 CFM
Sensor Accuracy:	Carbon Monoxide: ±5% @ 10 ppm Dew Point: ±2°F @ 50°F
Sensor Response Time:	<60 seconds
Keypad:	3-button touch, weatherproof w/tactile feedback
Battery Life:	10-12 hours (typical)
Data Logging:	2 points per minute
Data Storage Medium:	USB memory stick
Fittings:	Hansen
Inlet Pressure:	Maximum 150 psi
Total Air Capacity:	Maximum 15 CFM
Outlet Connection:	Supplied with one coupling
Inlet Port:	1/2 inch quick disconnect
Filter Train:	3-stages of filtration (5 micron, 0.01 micron, carbon adsorber)
Weight:	1 line: 19.2 lbs., 18.7" x 13.2" x 7.0"
Warranty:	2 years on sensors and monitor
Agency Approval:	UL 61010 U.S. CSA C22.2#61010-1 CA

Optional Models Available:

- 30 CFM Two Couplings
- 50 CFM Four Couplings
- 100 CFM Eight Couplings

Dimensions

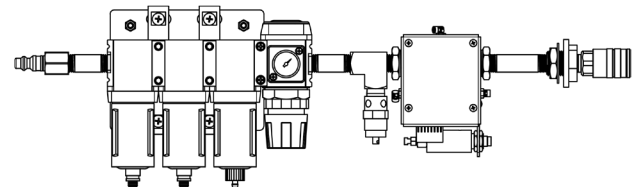
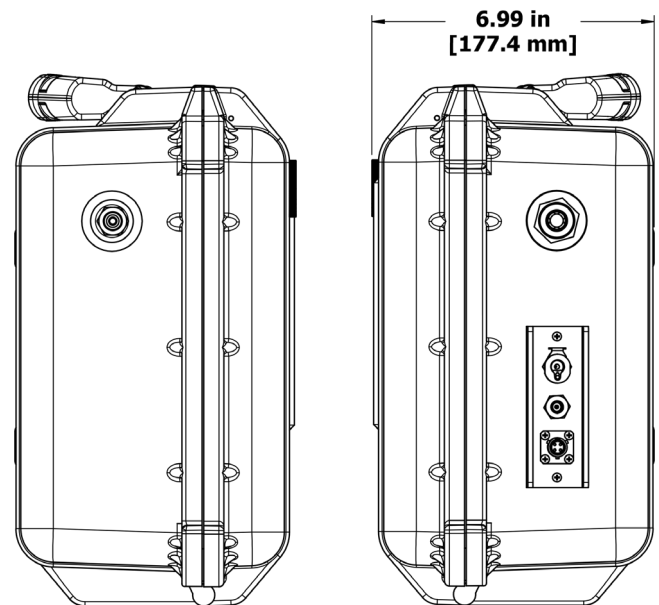
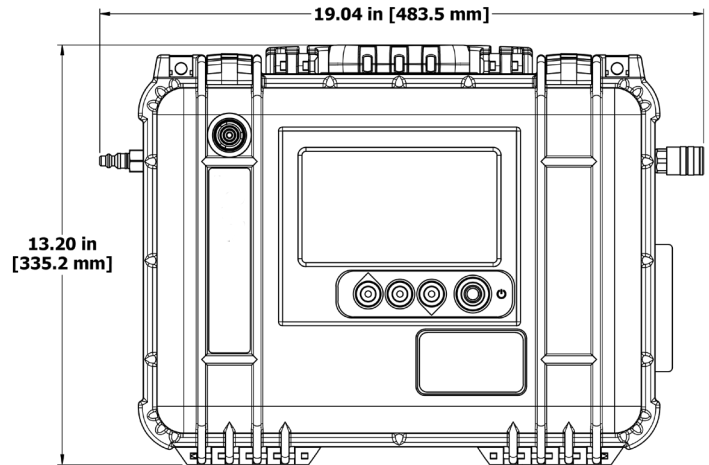

Bullard Center
2421 Fortune Drive
Lexington, KY 40509 • USA
877-BULLARD (285-5273)
Tel: +1-859-234-6616
Fax: +1-859-246-0243

Americas Operations
1898 Safety Way
Cynthiana, KY 41031 • USA
877-BULLARD (285-5273)
Tel: +1-859-234-6616
Fax: +1-859-234-8987

Bullard GmbH
Dieselstrasse 8a
53424 Remagen • Germany
Tel: +49-2642 999980
Fax: +49-2642 9999829

Bullard Asia Pacific Pte. Ltd.
51 Changi Business Park Central 2
#03-04 The Signature
Singapore 486066
Tel: +65 6745 0556

