



COHP CO Monitor User Manual

Air Source for COHP - CO Monitor Units

Industrial high pressure compressors that send compressed air into a storage air tank are normally the air source for these type of units. These Industrial compressors come with after-coolers and dryers, filters, CO monitors, and alarms as necessary to provide this high pressure compressed air. As the compressed air is distributed throughout a facility, certain areas may need additional CO monitoring if this air is being used as Grade D breathable air by workers. The Bullard COHP - CO Monitor units are a compact and convenient solution that provides this additional CO monitoring anywhere that it is required.

NOTE:

This COHP unit only monitors the CO content, in ppm, of the air source that is connected to this COHP unit.

This unit is designed to monitor breathing air for carbon monoxide contamination from a compressed air source. The air flows through the sampling hose and into the monitor where a small amount (~0.5 lpm) is diverted through a preset internal regulator and flow restrictor. This delivers a continuous flow of sample air to the sensor chamber. The monitor will analyze the air and display the CO concentration on the face of the monitor in parts-per million (ppm).

The Green LED located on the outside of the COHP will illuminate during normal operation when the CO level is below the CO alarm point (10 ppm US and 5 ppm International). If the CO level rises above the alarm set point, the Red LED on the outside of the COHP will illuminate and an audible alarm will sound.

The unit is housed in a protective polypropylene case that can be carried or mounted on a wall shelf. All system lights and alarms are located on the outside of the polycarbonate case. At least Grade D breathable air must be supplied to the system and must be free of oil and water to prevent contamination of the sensor. The monitor can operate on 115 or 230 VAC or 12 volts DC, as a backup battery.

WARNING

THE AIR SOURCE SHOULD BE REGULARLY SAMPLED TO CONFIRM IT CONTINUOUSLY MEETS AT LEAST GRADE D REQUIREMENTS, AT ALL TIMES. FAILURE TO READ, UNDERSTAND AND FOLLOW THIS INSTRUCTION COULD CAUSE DEATH OR SERIOUS INJURY OR LIFE-THREATENING DELAYED LUNG DISEASE INCLUDING BUT NOT LIMITED TO SILICOSIS, PNEUMOCONIOSIS OR ASBESTOSIS.

NOTE:

It is recommended that the COHP box be under the normal pressure setting that would be used during normal operation when calibrating the CO monitor.

Function Modes

The knob on the front of the COM10 or COM5 monitor sets the functions for the CO monitor and can be switched to RUN, TEST and CAL.

RUN mode is the operation/detection mode. The monitor must be in the RUN mode to monitor the supplied breathing air. Supplied air must be turned on and flowing to the instrument while in this mode. When the supplied air is off or interrupted while the monitor is in the RUN mode, the low flow alarm will sound and LF will be displayed on the monitor until the supplied air is turned on.

TEST mode allows for bump testing of the sensor or for silencing of the low flow alarm when supplied air is shut off. To perform a bump test, place the monitor in the TEST mode and flow the calibration gas into the center of the knob. The reading on the monitor should be 10 +/- 1 if applying CO gas. The reading on the monitor should be zero or 1 if applying the zero gas. In the test mode, the supplied air will not be monitored and there is no need to turn the supplied air off when entering this mode. Unit must be zeroed if bump test is performed with 10 ppm CO gas.

CAL is the CO calibration and zero calibration mode. When the monitor is switched to CAL, the supplied air will not be flowing to the sensor and there is no need to shut off the supplied air. When in the CAL mode, (AC) AutoCal® will be displayed. Pressing the On/Off button once while in this mode will change the display to (AO) AutoZero. For calibration and zeroing instruction, see the Calibration section.

F1 (fault) is indicated on the display when the knob is not positioned securely in one of these three modes.

⚠ indicates that the system requires a re-calibration

⚡ indicates a low battery

COHP Specs

Case Size: 17" W x 13"H x 7"D

| | |
|------------------------------|--|
| Weight: | 11 lbs |
| Case: | Pelican® |
| Monitor Display: | 2 digit LCD |
| Sensor Type: | Electrochemical; Carbon Monoxide |
| Detectable Range: | 0-99 ppm |
| Power: | 110/220VAC 50/60Hz or 12 volts DC backup |
| Operating Temperature: | -4° to 120°F (- 20° to 48.89°C) |
| Operating Pressure:..... | 10 psi - 120 psi |
| Calibration:..... | Manual CO and Zero - Auto-Cal - no manual adjustments required |
| Humidity Range: | 15% to 90% – Non-Condensing |
| Alarm Setting: | 10 ppm (5 ppm International) |
| Shielding:..... | Internal RFI/EMI coating on Monitor |
| Normal Operation: | Green LED/Light |
| Alarm Signals: | |
| High CO | Red LED light |
| High CO | Audible alarm (90dB) |
| Low Battery | Amber light (Blinking) |
| Low Battery | Audible alarm (chirp) |
| Low Flow | Audible alarm (90dB) |
| Warranty: | Two years on sensor only |

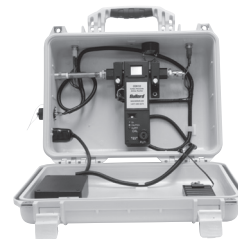

COHP Specs

| Description | Part Number |
|---|---------------|
| Carbon Monoxide Monitor | COM10 or COM5 |
| Remote Alarm Jack | |
| Inlet Fitting- Coulder Coupler | |
| Pressure Relief Valve | 41PRV |
| Sampling Connector Kit | COHPKIT |
| Includes: | |
| 3/8" x 1/4" Adaptor | |
| Colder Coupler | |
| Tee fitting | |
| Reinforced Sampling tube with Colder plugs - 5 ft. length | |

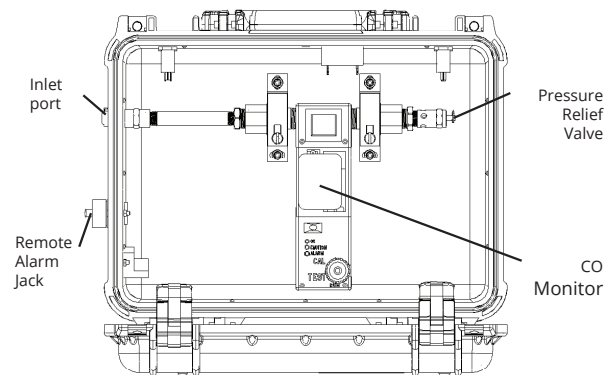

California Proposition 65 WARNING

Cancer and Reproductive Harm - www.P65Warnings.ca.gov.

Propuesta de California 65 ADVERTENCIA

Cáncer y Daño Reproductivo - www.P65Warnings.ca.gov.

Proposition de la Californie 65 AVERTISSEMENT

Cancer et Troubles de l'appareil reproducteur - www.P65Warnings.ca.gov.

Set Up

Identify and secure a Grade D breathable air source with pressure under 150 psig. Using the fittings included in the COHPKIT, connect the COHP monitor to the air source.

Connecting to the Breathable Air Source that needs to be sampled.

To connect the COHP sampling hose to the Air Source Piping, screw the Colder coupler into a 1/4" NPT Female Sampling Connection. This is the point at which the sampling hose will connect. Also included in the kit is an adaptor which will allow for the use of the 3/8" NPT Bushing to connect to the Colder coupler, if necessary.

Attach the other end of the sampling hose to case via the Colder coupler connection on the side of the COHP (Figure 1).

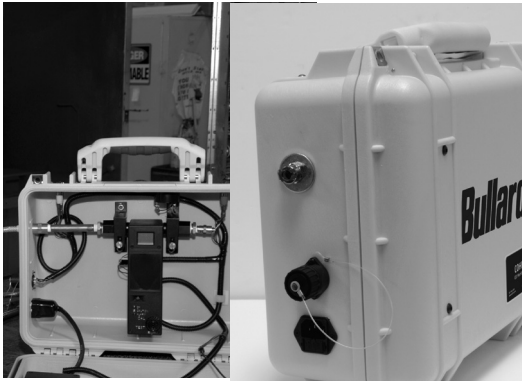

Fig. 1

Monitor Operation

Connect the AC cord to the power inlet on the side of the COHP and then plug the cord into the AC power source.



NOTE: This unit may be operated using DC power – 8 ea. AA batteries if no AC power is available. See Optional DC Power Supply information

Flip the switch on the Control Box to ON position (Figure 2).



Fig. 2

Ensure the knob on the CO Monitor is rotated to the TEST position. This will prevent the Low Flow alarm from sounding during start up if no air is flowing.

Push the ON button located behind the front cover of the CO Monitor (Figure 3).

Wait for the 60 second countdown shown on the CO Monitor display screen.

Calibrate the CO Monitor if necessary. See Calibration Instructions.

Connect the RA remote alarm assembly (optional) to the remote alarm jack.

With air pressure connected to the Sampling Port on the COHP unit, turn knob to RUN.



NOTE: The knob must be in RUN position for active monitoring of the CO in the air supply.

Shutdown

The monitor can be left "ON" continuously when being operated on 115VAC. If operating on the optional AA battery backup power, it is recommended that the control box and the monitor be turned off when not in use to reserve battery power.

- 1) Turn off the main air supply to the monitor.
- 2) Turn monitor OFF at the ON/OFF switch located behind the front cover of the

CO Monitor. You will hear three short beeps to let you know the monitor is OFF.

- 3) Turn the control box switch to the OFF position.

Zero-Point and Calibration Process



NOTE: It is recommended that the COHP box be under the normal pressure setting that would be used during normal operation when calibrating the CO monitor.



NOTE: If monitor has been relocated to a different working area and ambient temperatures change, allow the unit to stabilize for 15-20 minutes prior to Zero Point adjustment and calibration.

Zero-Point Adjustment

Zero calibration should be performed before calibrating the monitor with CO gas. Bullard recommends using impurity free test gas to re-zero and whenever the zero-point has drifted.

Zero-Point Adjustment Procedure

Remove the front cover of the CO Monitor

Push the ON button. The unit will beep and begin a 60 second countdown.

Rotate the knob located on the front of the CO Monitor the CAL position.

"AC" will appear on the display.

Press and hold the ON/OFF button until the unit beeps.

"AO" will appear on the display.

Attach the calibration valve to the Zero gas cylinder

Insert the calibration connector fitting into the center of the knob on the front of the monitor.

Open the cylinder valve fully. The flow rate is preset so there is no need to adjust it.

The red LED will continue to blink for 90 seconds during which the Zero Adjustment process will take place.

Watch for the green LED to begin blinking. This indicates a successful zero.

With the Zero air still flowing, turn the knob to TEST. The reading should alternate between Co and 1 or 0. If any other reading is displayed, repeat the Zero Point Adjustment.

Close the cylinder valve completely and remove the calibration connector fitting from the center of the knob.



With the incoming air pressurized, turn the knob to RUN.



NOTE: Knob must be in the RUN position for active monitoring of CO in the air supply

Calibration Instructions

The COM5 and COM10 are Auto-Cal instruments. All calibration adjustments are made by the microprocessor.

Monitor calibration should be performed monthly or whenever the reading may be questionable. A calibration schedule should be maintained for future reference. To obtain an accurate calibration, we recommend the use of Bullard calibration kits.

Calibration Procedure

Remove the front cover of the CO Monitor, and if necessary, push the ON button.

Rotate the knob located on the front of the monitor to the CAL position.

"AC" will appear on the display.

Attach the regulator to the calibration gas cylinder (10 ppm CO required).

Insert the calibration connector fitting into the center of the knob.

Open the cylinder valve fully. The flow rate is preset and there is no need to adjust it.

The Red LED on the front of the monitor will continue to blink for 90 seconds during which the calibration process will take place.

Watch for the green LED to blink. This indicates a successful calibration.

With the 10ppm gas still flowing, turn the knob to TEST. The reading should alternate between Co and 10 (+/- 1). If any other reading is displayed in the test mode, repeat both the Zero Point adjustment and CO calibration.

Close the regulator on the CO gas cylinder completely and remove the calibration connector fitting from the center of the knob.

Rotate the knob to the RUN position.



Fig. 3

COHP CO Monitor User Manual

NOTE:
Typical calibration takes approximately 90 seconds. If unit will not calibrate within 3 minutes, repeat the calibration steps with compressed air turned off. If the problem persists, contact Bullard's Customer Service Department at 1-877-BULLARD (285-5273).

NOTE:
Cam valve switch must be in RUN position for active monitoring of CO in the air supply.

Battery Replacement

A 9-volt battery is installed under the front panel cover to provide power to the CO monitor. This monitor may also run solely on AC power if the COHP attached to an AC power supply. Regardless of AC or DC power to the CO monitor, a 9 volt DC battery MUST be installed in the CO monitor at all times.

To replace the 9-volt battery, remove the panel cover from the front of the CO monitor. Lift it off from either the left or right side. If a 9-volt battery is being used to power the monitor and the battery power becomes too low, the monitor will indicate low battery (LB) on the display to indicate it is time to change the battery (Figure 4).

Optional DC Power Supply

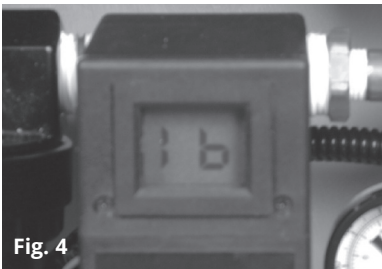

Fig. 4

The COHP may be operated using 8 AA batteries to provide power to the external lights and alarm and the CO Monitor. During DC operation, the unit will operate continuously for 40 hours. Alarm status and duration can affect length of operation when using the DC backup power supply.

Lights located on the box will indicate whether the box is being operated on AC or DC power. If

the COHP being operated with backup DC power (8 AA batteries), the amber light on the top of the box will burn steady. If the battery power for the box falls below the required voltage, the amber light on the top of the box will flash indicating it is time to change the batteries. There will also be an audible alert in the form of short, intermittent beeps that will serve as notification that the batteries are low. The battery compartment is located on the interior surface of the COHP case (Figure 5).

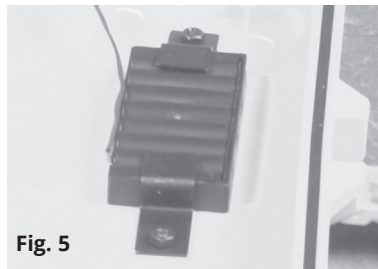

Fig. 5

Sensor Replacement

ATTENTION

Before installing a replacement sensor, verify that you have the correct sensor. The CABRS is the replacement sensor for all COM10 or COM5 monitors with serial numbers with a suffix "A," and serial numbers with NO suffix. The CABRS2 is the replacement sensor for all COM10 or COM5 monitors with serial numbers with a suffix "B." Also, the monitors that require the CABRS2 will have an extra board to which the sensor mounts. See photos below to view the two sensors.



CABRS



CABRS2

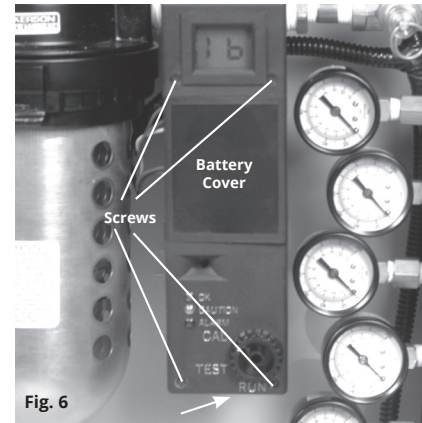

Fig. 6

The sensor is easily accessible by removing the front of the housing from the COM5 or COM10 monitor.

To gain access to the sensor, remove the four screws on the front of the CO monitor only. After removing the four screws, gently pry the front of the housing off from the bottom of the housing.

WARNING

Removing the front of the housing by prying at the top will result in damage to the housing and render the product unsafe for use. This damage is not covered under warranty.

Gently pull out the old sensor.

Remove the shorting clip cover from the new sensor.

Align pins and gently push the new sensor into the sockets.

Replace the front cover of the monitor when the sensor replacement is complete. Ensure LED lights are aligned with housing before securing the front cover with screws.

After replacing the sensor, allow the instrument to warm up for at least 30 minutes. The new sensor must be zeroed and calibrated before first use. See Zero-Point Adjustment and Calibration Instructions.

One Year LIMITED Warranty

Bullard warrants to the original purchaser that the CO Monitor will be free of defects in material and workmanship under normal use and service for a period of one (1) year from the date of purchase. Bullard's obligation under this warranty is limited to repairing or replacing, at its option, parts that are returned within the warranty period and that are, after examination, shown to Bullard's satisfaction to be defective, subject to the following limitations.

- CO Monitor must be returned to the Bullard factory with shipping charges prepaid.
- CO Monitor must not be altered from its original factory configuration.
- CO Monitor must not have been misused, subjected to negligent use, or damaged in transport.
- The date of purchase is within the one year warranty period. (A copy of the purchaser's original invoice showing the date of purchase is required to validate warranty coverage.)

In no event shall Bullard be responsible for damages for loss of use or other indirect, incidental, consequential or special costs, expenses or damages incurred by the purchaser, notwithstanding that Bullard has been advised of the possibility of such damages.

ANY IMPLIED WARRANTIES, INCLUDING WARRANTIES OF MERCHANTABILITY AND FITNESS FOR A PARTICULAR PURPOSE, ARE SPECIFICALLY EXCLUDED FROM THIS WARRANTY.

Some states do not allow the exclusion or limitation of incidental or consequential damages, or allow limitations on how long an implied warranty lasts, so the above limitations or exclusion may not apply to you. This warranty gives you specific legal rights, and you may have other rights which vary from state to state.



Return Authorization

The following steps must be completed before Bullard will accept any returned goods. Please read carefully.

Follow the steps outlined below to return goods to Bullard for repair or replacement under warranty or for paid repairs:

1. Contact Bullard Customer Service by telephone or in writing at:

Bullard
 1898 Safety Way
 Cynthiana, KY 41031-9303
 Toll-Free: 877-BULLARD (285-5273)
 Phone: 859-234-6611

In your correspondence or conversation with Customer Service, describe the problem as completely as possible. For your convenience, the representative will try to help you correct the problem over the phone.

2. Verify with your representative that the product should be returned to Bullard. Customer Service will provide you with written permission and a return authorization number.
3. Before returning the product, decontaminate and clean it to remove any hazardous materials which may have settled on the product during use. Laws and/or regulations prohibit the shipment of hazardous or contaminated materials. Products suspected to be contaminated will be professionally discarded at the customer's expense.
4. Ship returned products, including those under warranty, with all transportation charges pre-paid. Bullard cannot accept returned goods on a freight collect basis.
5. Returned products will be inspected upon return to the Bullard facility. Bullard Customer Service will telephone you with a quote for required repair work which is not covered by warranty. If the cost of repairs exceeds stated quote by more than 20%, your representative will call you for authorization to complete repairs.

CO Monitor Troubleshooting Guide

| | |
|--|--|
| Monitor will not calibrate at 10 ppm. | <ol style="list-style-type: none"> 1. Prior to performing a calibration, allow the temperature of the monitor to stabilize to the environment in which it will be used for several minutes. 2. The COHP Box should be under pressure with air pressurizing the CO Monitor. (i.e. under static pressure). 3. Perform a zero point adjustment using impurity-free air. 4. If the instrument zeroes, perform a calibration using 10 ppm CO. 5. Verify that the calibration gas is 10 ppm and the gas cylinder is not empty. (Gauges are available.) 6. If the instrument will not calibrate, remove the air supply and repeat both the zero point adjustment and the 10 ppm CO calibration. 7. If the instrument will not calibrate, replace the sensor and repeat both the zero point adjustment and the 10 ppm CO calibration. |
| Monitor will not successfully complete a zero point adjustment. | <ul style="list-style-type: none"> • Wait 5 minutes and repeat steps 1-4 above. |
| Monitor displays a (-0) reading or rc. | <ul style="list-style-type: none"> • Wait 5 minutes and repeat steps 1-6 above. |
| Monitor zeroes during the zero point adjustment and the reading elevates after returning to the RUN mode. | <ol style="list-style-type: none"> A. Allow unit to stabilize in the run mode for 5 minutes. B. Repeat steps 1-6 above. C. If the unit will not calibrate, the supply air may be contaminated. D. Check the supply air for CO level. |
| Monitor will not turn ON. | <ul style="list-style-type: none"> • Verify that the ON/OFF button under the front cover of the monitor has been pressed to activate the monitor • Check AC power supply <ol style="list-style-type: none"> 1. Confirm the ON/OFF switch on the control box is in the ON position 2. Confirm AC power cord is connected to working outlet 3. Confirm unit is wired correctly • Using Battery back up <ol style="list-style-type: none"> 1. Confirm the AA batteries are good – replace if needed • Using 9V battery installed in monitor <ol style="list-style-type: none"> 1. Verify that the battery is good – replace if needed ⚠ NOTE Monitor will not turn ON without a 9V battery installed in the correct position. Reversing the + and - poles will prevent the monitor from functioning too. • If the power supply is good and the monitor will not power up, return it to the factory for repair or replacement. |
| Monitor does not display flashing green light after calibration or a partial display appears on the monitor screen. | <ul style="list-style-type: none"> • With the monitor ON and the unit on battery power only, remove and reinstall the 9 volt battery. ⚠ NOTE 9V battery must be good for this step to work. • Repeat steps 1-6 above. |
| Monitor does not turn OFF. | <ul style="list-style-type: none"> • Monitor must be switched to the RUN or TEST mode for monitor to turn OFF. |
| Monitor displays an (F1) reading. | <ul style="list-style-type: none"> • The rotary cam switch is not locked in the CAL, TEST or RUN position. • Turn the switch knob slightly until it is in the correct position. ⚠ NOTE <ol style="list-style-type: none"> 1. AC appears on the display if attempting to go to CAL mode. 2. CO and an alternating number appears on the display if the unit is in the TEST mode. 3. A number (PPM content of CO in the compressed air) appears on the display if attempting to go to the RUN mode. |
| Monitor displays (8.88, 2F or 9E) with flashing lights. | <ul style="list-style-type: none"> • This can occur when the ON / OFF button is pushed while the monitor is in the fault mode with F1 showing on the display. • Continue to push the ON / OFF button until F1 is shown on the display. • Turn the switch knob slightly to lock the monitor into the CAL, TEST or RUN mode. |
| Monitor shuts down after 60 second countdown. | <ul style="list-style-type: none"> • Check power supply. • Verify that the 9V battery and the AA batteries are good. • If the power supply is good and the monitor will not power up, return it to the factory for repair or replacement. |
| Monitor displays "lb". | <p>This indicates a low battery condition and the 9V battery in the CO monitor should be replaced.</p> |
| Yellow caution LED flashes. | <ul style="list-style-type: none"> • This is normal for TEST mode and no action is necessary. • If the unit is not in TEST mode, then it may indicate a low battery condition. Replace the 9V battery in the CO monitor. |

Bullard Center
 2421 Fortune Drive
 Lexington, KY 40509 • USA
 877-BULLARD (285-5273)
 Tel: +1-859-234-6616
 Fax: +1-859-246-0243

Americas:
E.D. Bullard Company
 1898 Safety Way
 Cynthiana, KY 41031-9303
 Toll free: 877-BULLARD (285-5273)
 Tel: 859-234-6616
 Fax: 859-234-8987

Europe:
Bullard GmbH
 Dieselstrasse 8a
 53424 Remagen • Germany
 Tel: +49-2642 999980
 Fax: +49-2642 9999829

Bullard Asia-Pacific Pte. Ltd.
 51 Changi Business Park
 Central 2
 #03-04 The Signature
 Singapore 486066
 Tel: +65 6745 0556



©2024 Bullard. All rights reserved.
 6081257991D (0224)