



## Product Highlights

- CO and differential dew point sensors
- Reduces oils, solid particles, water and unpleasant odors
- Respirator CFM and sensor flow alarms
- Visual and audible alarm warnings
- Datalog - OSHA compliance records
- Portable - battery operated, rechargeable

AirGuard is an innovative next-generation solution in portable air quality products. It integrates supplied air filtration with sensors for Carbon monoxide (CO) and differential dew point for both safety and supplied air comfort.

Designed with the user in mind, AirGuard has an external easy-to-read display to communicate threats beyond general audible alarm warnings. The display can be readable from over 30 feet allowing for a quick response when AirGuard detects a hazardous situation. Using its menu-driven interface, AirGuard is easy to operate. It provides a system status upon power up and most importantly keeps track of the sensor and function status and calibration interval. The AirGuard data log records all the real-time sensor data, calibration events, and diagnostic data over time. This data is easily downloadable to a PC using the removable USB drive for operational record keeping and OSHA compliance reporting.

The AirGuard model AGD15HA has a 15 CFM capacity with 1 output connection for NIOSH approved supplied-air respirators. AirGuard has a state of the art three-stage air filtration system that helps remove oils, water, solid particles, and unpleasant odors.

## Ordering Information

Description	Part No.
AirGuard - 1 Worker, 15CFM with Industrial Interchange Quick Disconnect Coupling	AGD15HA
Remote Alarm - Includes 100ft of cable	AGDRA
Calibration Kit - Includes Case, Regulator, Tubing, Quick Connector, 10PPM Cylinder and Zero Air Cylinder	AGDCK
Filter Replacement - 15CFM Filter Element Kit for all 3 stages of filtration	AGD15FK



# AirGuard Series Portable Air Quality Box

## 15 CFM, 1 Airline Connection Technical Specifications

### General Specifications

<b>Display:</b>	Backlit, 7" diagonal color display
<b>Alarms:</b>	User programmable
<b>Air Flow Alarm Pt:</b>	Carbon Monoxide 5 or 10 PPM < 3 CFM
<b>Sensor Types:</b>	Carbon Monoxide 0 to 50 ppm Dew Point -20°F to ambient Flow Rate 0 to 100 CFM
<b>Sensor Accuracy:</b>	Carbon Monoxide: ±5% @ 10 ppm Dew Point: ±2°F @ 50°F
<b>Sensor Response Time:</b>	<60 seconds
<b>Keypad:</b>	3-button touch, weatherproof w/tactile feedback
<b>Battery Life:</b>	10-12 hours (typical)
<b>Data Logging:</b>	2 points per minute
<b>Data Storage Medium:</b>	USB memory stick
<b>Fittings:</b>	Industrial Interchange / Hansen Compatible
<b>Inlet Pressure:</b>	Maximum 150 psi
<b>Total Air Capacity:</b>	Maximum 15 CFM
<b>Outlet Connection:</b>	Supplied with one coupling
<b>Inlet Port:</b>	1/4 inch quick disconnect
<b>Filter Train:</b>	3-stages of filtration (5 micron, 0.01 micron, carbon adsorber)
<b>Weight:</b>	20.8 lbs.
<b>Warranty:</b>	2 years on sensors and monitor
<b>Agency Approval:</b>	UL 61010 U.S. CSA C22.2#61010-1 CA

### Dimensions

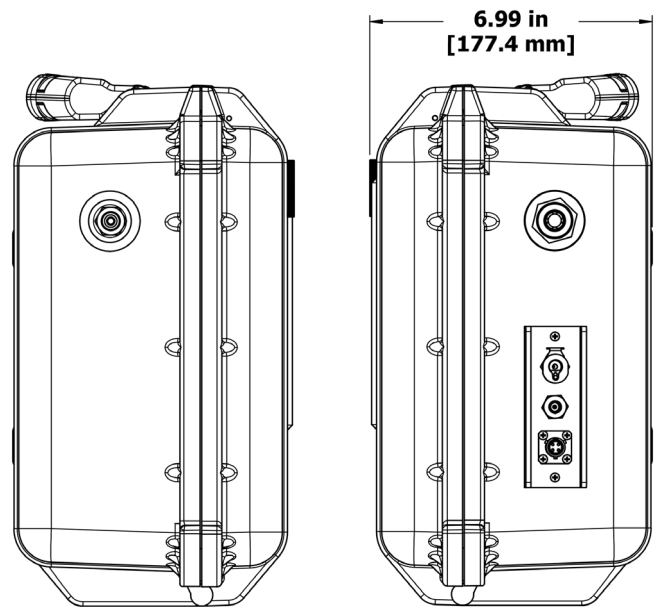
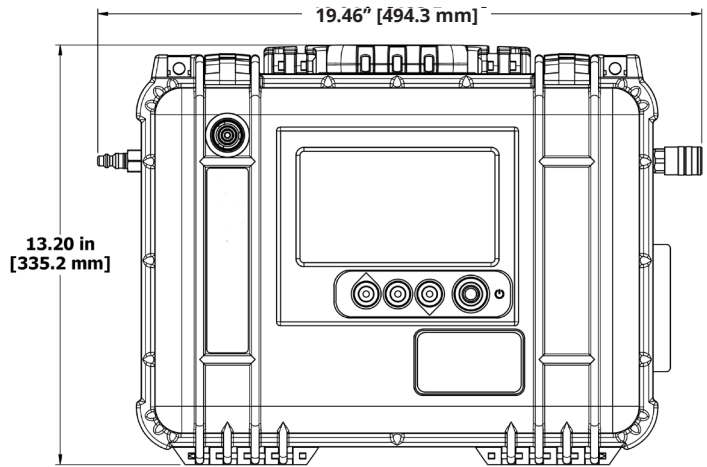

### Optional Models Available:

- 30 CFM Two Couplings
- 50 CFM Four Couplings
- 100 CFM Eight Couplings

**Bullard Center**  
2421 Fortune Drive  
Lexington, KY 40509 • USA  
877-BULLARD (285-5273)  
Tel: +1-859-234-6616  
Fax: +1-859-246-0243

**Americas Operations**  
1898 Safety Way  
Cynthiana, KY 41031 • USA  
877-BULLARD (285-5273)  
Tel: +1-859-234-6616  
Fax: +1-859-234-8987

**Bullard GmbH**  
Dieselstrasse 8a  
53424 Remagen • Germany  
Tel: +49-2642 999980  
Fax: +49-2642 9999829

**Bullard Asia Pacific Pte. Ltd.**  
51 Changi Business Park  
Central 2  
#03-04 The Signature  
Singapore 486066  
Tel: +65 6745 0556



©2024 Bullard. All rights reserved.